

PNEUMATIC RANDOM ORBITAL SANDER MANUAL INSTRUCTION



NT09-525C-HD

NT09-550C-HD

ATTENTION! PLEASE READ THIS MANUAL BEFORE USING THE TOOL.

IMPROPER USE OF TOOL MAY CAUSE INJURY AND/OR PROPERTY DAMAGE!

ONLY QUALIFIED AND SPECIALLY TRAINED PERSONNEL FAMILIED WITH THESE INSTRUCTIONS IS ALLOWED TO USE AND MAINTENANCE OF THE TOOL.

This manual contains description, safety rules and all the information necessary for the correct use of the pneumatic tool.

The safety advice given in this manual is in addition to and does not replace the general safety regulations applicable in the region where the Tool is used.



- **Potential injury from moving parts.**
- **There may be an increased level of noise, vibration.**
- **Excessive dustiness of the air in the working area may occur.**



GENERAL RULES OF OPERATION

- When working with the tool always use personal protective equipment appropriate for the type of work performed (goggles, impact resistant glasses, hand protection, body, etc.);
- The employee's appearance must comply with safety requirements. Loose clothing, jewelry or long hair can be caught in the rotating parts of the tool;
- The rated speed of the accessories used must exceed the maximum indicated tool speed;
- To ensure maximum performance and durability of the tool, the working pressure of the compressed air should be set at 6,2 bar;
- Do not operate the tool in an explosive environment containing flammable liquids, gases, or dust. During operation, sparks may form, from which ignition is possible;
- High noise levels can cause hearing loss. Timely maintenance will help avoid an increase in noise levels;
- The tool may generate vibration during use. Prolonged vibration can damage hands and / or other parts of the body. In case of any unpleasant sensations in the hands and wrists, you must stop working;
- The flow of compressed air can cause serious injury. Never direct the air flow towards yourself or others. Do not use compressed air to clean clothes;
- Before starting work, check the compressed air supply and dust extraction hoses for damage, wear or other defects. Replace immediately if found;
- Do not carry the tool by the compressed air supply and dust extraction hoses;
- Check screw connections before starting work. Tighten if necessary;
- Possible sudden changes in movement during start-up and operation;
- Do not try to lock the ON / OFF lever in the ON position. The lever should independently and freely return to the "OFF" position after being released;
- The workpiece to be processed must be securely fixed;
- Always disconnect the tool from the compressed air line before changing abrasives, accessories, performing maintenance or adjusting parameters;
- Before installing on the tool, inspect the abrasives (accessories) for damage or defects.

MAINTENANCE

- This type of tool does not require daily maintenance.
- Before and after operating, place a few drops of SAE #10 into inlet bushing with throttle lever pressed down to allow lubricating oils to properly dispense through machine.
- Connect the compressed air pipe and run for a few seconds, the tool for oil distribution on the tool.

NOTE: it is Possible the yield of oil through the exhaust hole. To prevent the ingress of oil on the workpiece and / or of the operator to close the exhaust hole with a rag.

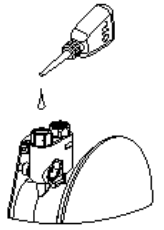

STORAGE

- Avoid storing the instrument in conditions of high humidity.
- Lubricate the tool before long-term storage (see MAINTENANCE).

ITEM DESIGN HANGE

It is forbidden to make changes to the design of the tool without the consent of the manufacturer.

DISPOSAL

When disposing of the tool or individual components, observe the local regulations in force in the region where the equipment is used.

THE AIR SUPPLY SYSTEM

- For maximum performance and durability of parts, the operating inlet pressure should be set at 6,2 bar.
- Recommended diameter of the compressed air hose 3/8" (≈ 9 mm).
- Always use clean, dry air.
- Drain the water from the air line before starting work. Install a filter drier in the air line.
- Maintain the necessary supply of compressed air in the air line for trouble-free and optimal tool performance.

EXAMPLE OF AIR SUPPLY SYSTEM

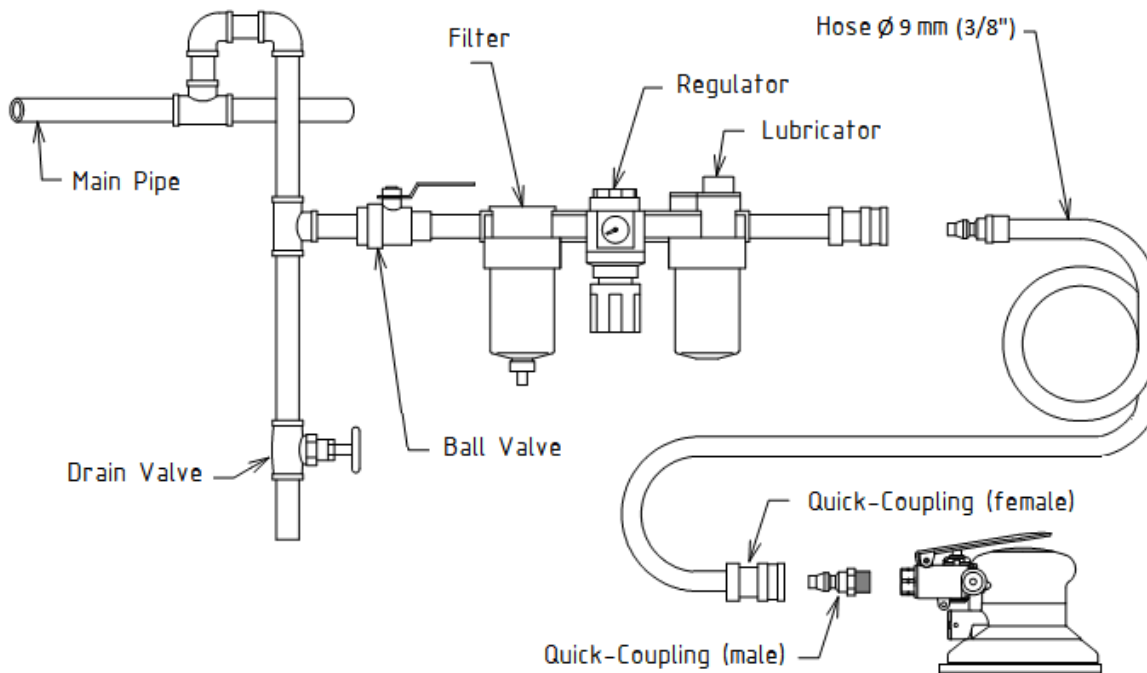

TYPES OF DUST EXTRACTION

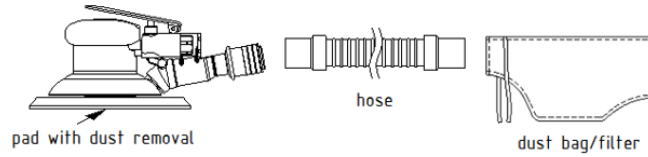

Type of dust extraction: **SELF-GENERATED VACUUM** (with the bag filter)

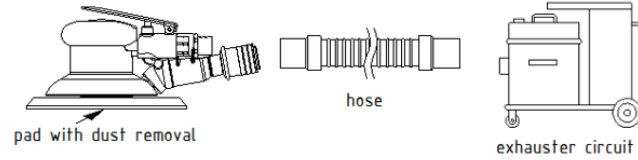

Type of dust extractoin: **CENTRAL VACUUM**

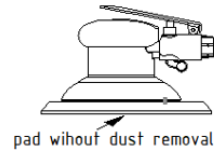

Type of dust extractoin: **NON-VACUUM**

TECHNICAL SPECIFICATION

Model	Pad size, mm	Orbit, mm	Speed, rpm	Air consumption, lpm	HP	Vacuum mode	Pad Face
NT09-525C-HD	152	2,5	12 500	450	0,3	Central Vacuum	Hook
NT09-550C-HD	152	5	12 500	450	0,3	Central Vacuum	Hook

Working pressure, bar	Air inlet thread	Noise, dB (A)
6,2	1/4"	≤ 90,5

TROUBLESHOOTING GUIDE

Not operating	
Possible Cause	Solution
Blades broken or worn out	Replace blades
Ball bearing damaged	Replace ball bearing
Rusty Motor or clogged with objects	Disassemble and repair
Motor blades stuck	Disassemble and repair
Regulator is set at «OFF»	Adjust regulator
No air flow	Check air system and connections
Valve set damaged or broken	Disassemble and repair
Low efficiency	
Possible Cause	Solution
Not enough air pressure	Check air pressure
Regulator is not set properly	Adjust regulator
Motor running abnormal or unusual noises occur	
Possible Cause	Solution
Not enough lubrication	Lubricate
Ball bearing, cylinder, rotor blade, shaft damaged	Replace parts
Motor keeps running	
Possible Cause	Solution
Valve set has other objects stuck on it	Remove foreign objects
Throttle valve or spring broken	Disassemble and repair
Valve seat broken, damaged	Disassemble and repair
Throttle valve broken	Replace parts

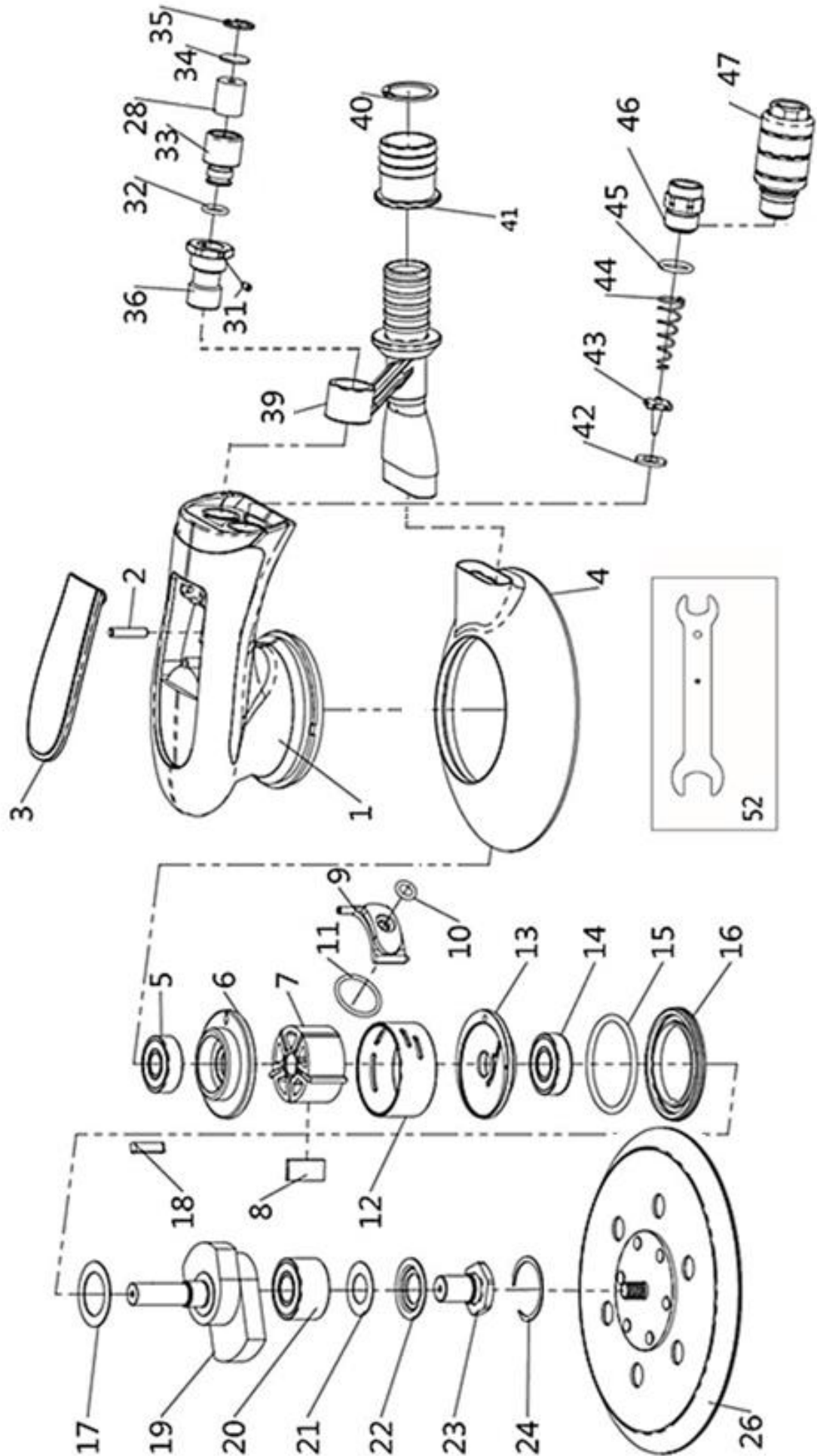

No.	Description	Part No.	Q'ty
1	Motor Housing	NT09S-0399	1
2	PIN	NT09S-0400	1
3	Valve Lever	NT09S-0401	1
4	152 mm Vac. Shroud	NT09S-0404	1
5	Ball Bearing	NT09S-0405	1
6	Upper End Plate	NT09S-0406	1
7	Rotor	NT09S-0407	1
8	Blade	NT09S-0021	5
9	Intake positioning block	NT09S-0408	1
10	O-Ring	NT09S-0024	1
11	O-ring	NT09S-0409	1
12	Cylinder	NT09S-0410	1
13	Lower End Plate	NT09S-0411	1
14	Ball Bearing	NT09S-0412	1
15	O-Ring	NT09S-0027	1
16	Retainer Nut	NT09S-0028	1
17	Felt	NT09S-0054	1
18	Pin	NT09S-0413	1
19	Shaft, 2.5 mm (152 mm)	NT09S-0416	1
	Shaft, 5 mm (152 mm)	NT09S-0417	1
20	Ball Bearing	NT09S-0038	1
21	Dust Seal	NT09S-0039	1
22	Washer	NT09S-0040	1

No.	Description	Part No.	Q'ty
23	Pad Retainer	NT09S-0042	1
24	Retaining Ring	NT09S-0041	1
26	152 mm Vac. Hook Face Pad (6 hole)	NT09S-0050	1
	152 mm Vac. Hook Face Pad (15 hole)	NT09S-0052	1
28	Muffler	NT09S-0071	1
31	Screw	NT09S-0067	2
32	O-Ring	NT09S-0069	1
33	Swivel Muffler	NT09S-0070	1
34	Plate	NT09S-0072	1
35	Snap Ring	NT09S-0073	1
36	Central Vac. Retainer	NT09S-0068	1
39	Self-Gen. Vac. Retainer	NT09S-0419	1
40	Snap Ring	NT09S-0062	1
41	Swivel Hose Adapter	NT09S-0059	1
	Swivel Hose Adapter	NT09S-0060	1
	Swivel Hose Adapter	NT09S-0061	1
42	Valve Seat	NT09S-0008	1
43	Throttle Valve	NT09S-0009	1
44	Spring	NT09S-0420	1
45	O-Ring	NT09S-0076	1
46	Hose Fitting	NT09S-0011	1
47	Guide ring ontology	NT09S-0421	1
52	Pad Wrench	NT09S-0053	1



info@onetech-tools.com



www.onetech-tools.com

